

Actuated Valves

Type 27511 - Pneumatic Actuator - Globe Valve (on/off)



Pneumatic Actuators for Globe Valves (on/off)

Actuator - air to open, **spring to close**
 maximum air pressure for operation 6.0 bar g
 Actuator coating outside - Epoxy resin

Available options - on request only:
 - Pneumatic actuator with override handwheel

Ambient temperature limit: -20°C / -4°F (253K) up to +80°C / 176°F (353K)

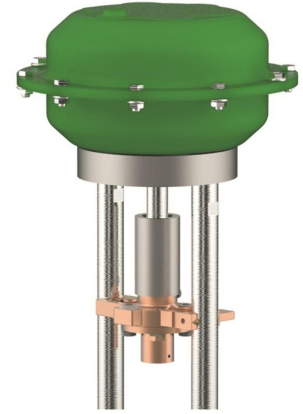

Overview - required actuator sizes for differential pressures

Valve-size	Differential pressure in bar												
	3	4	7	10	11	15	18	20	22	30	33	35	50
DN 10	A	A	A	A	A	A	A	A	A	A	A	A	A
DN 15	A	A	A	A	A	A	A	A	A	A	A	A	A
DN 20	A	A	A	A	A	A	A	A	A	A	B	B	B
DN 25	A	A	A	A	A	A	A	A	B	B	B	B	B
DN 32	A	A	A	A	A	B	B	B	B	B	B	B	C
DN 40	B	B	B	B	B	B	B	B	B	C	C	C	C
DN 50	B	B	B	B	B	B	C	C	C	C	C	C	D
DN 65	B	B	B	C	C	C	C	D	E	E	E	F	F
DN 80	B	B	C	C	D	E	E	E	E	F	F	F	G
DN 100	B	C	D	E	E	F	F	F	F	G	o.r. - on request		
DN 150	D	E	F	G	o.r. - on request								

Code in Table	Part No.	Actuator
A	27511.15A6.3SPO	
B	27511.35B6.6GPO	
C	27511.60A6.6GPO	
D	27511.60C6.7GPO	
E	27511.75B6.3DPO	
F	27511.75B6.5DPO	
G	27511.75B6.7DPO	

Materials	DIN EN	ASTM
1 Body	1.0333	A 619 Grade 1008
2 Body	1.0333	A 619 Grade 1008
3 Diaphragm	NBR	
4 Springs	1.1200	A 576 Grade 1045
5 Actuator stem	1.4301	A 276 Grade 304
6 Coupling	CC333G	B 148 UNS C95800

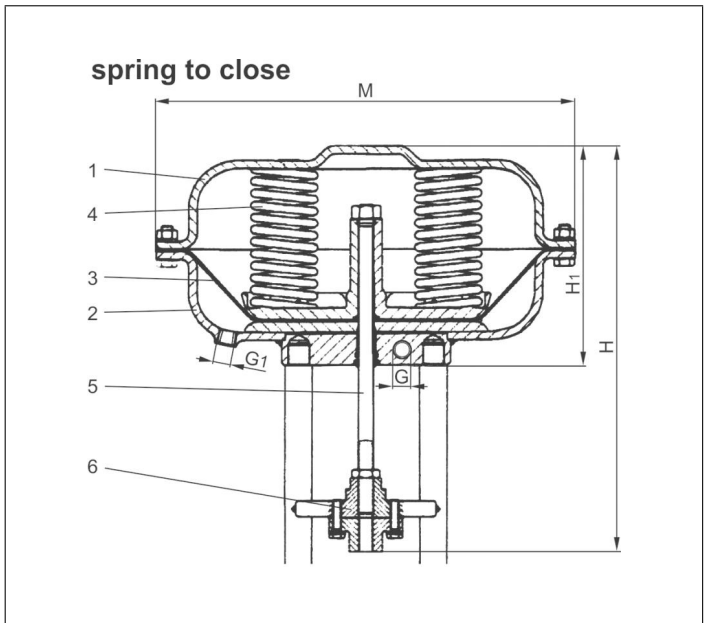

Type 27511		Technical data						
Part No.	Actuator	27511						
		.15A6.3SPO	.35B6.6GPO	.60A6.6GPO	.60C6.7GPO	.75B6.3DPO	.75B6.5DPO	.75B6.7DPO
Diameter Actuator	M	162	210	310	310	430	430	430
Height	H	256	276	309	352	353	353	353
Height	H1	116	136	166	186	234	234	234
Thread	G	G1/8" with Ermeto-Fitting L8	-	-	-	-	-	-
Thread	G1	-	1/4" NPT	1/4" NPT	1/4" NPT	1/4" NPT	1/4" NPT	1/4" NPT
Diaphragm area	cm ²	120	280	530	530	1000	1000	1000
Spring rage	bar	0.9 - 2.0	0.8 - 3.0	0.8 - 2.8	0.7 - 3.0	0.7 - 2.1	1.2 - 3.4	1.6 - 4.7
Regulating lift	mm	20	35	40	60	60	60	60
Weight	ca. kg	3.0	5.0	12.5	14.0	37.0	39.0	41.0

Dimensions in mm.